

Nuovo cilindro per scarrabili

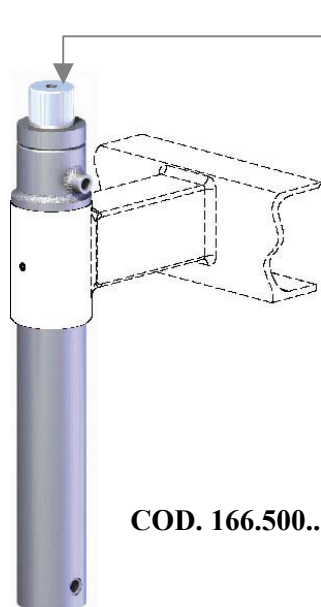

COD. 166.500.....

Cilindri oleodinamici doppio effetto appositamente studiati per l'allestimento di attrezzature scarrabili per casse mobili su veicoli medi e pesanti.

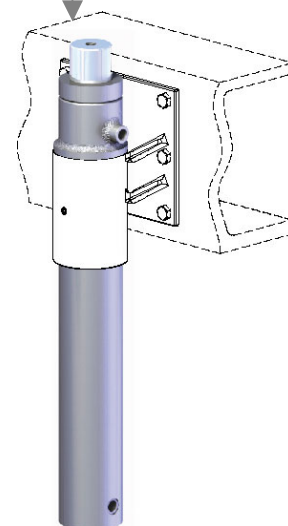

COD. 166.500.....

I cilindri possono essere fissati direttamente al telaio con gli accessori forniti separatamente:

Collare da saldare ad una traversa
COD. 166.501.00101

Manicotto da saldare alla traversa
COD. 114.904.00121

Piastra da imbullonare al telaio
COD. 166.501.00049



Codice ordinazione Order Code	Alesaggio Diameter mm	Stelo Rod mm	Corsa Stroke mm	Pressione max. di lavoro Max working pressure Bar	Spinta@100Bar Thrust@100Bar Kg	Peso Weight Kg
166-500-80302	80	60	300	250	5000	
166-500-80357			350			
166-500-80400			400			
166-500-80455			450			
166-500-80508			500			